



# AVENTURA RALLY 307

## EURO 5+



**OWNER'S MANUAL**





**RIEJU S.A.** would like to thank you for your trust in our company and congratulate you on an excellent choice.

The **AVENTURA RALLY 307 Euro 5+** model is the result of **RIEJU'S**, extensive experience in developing high-performance vehicles.

The purpose of this Owner's Manual is to set forth how to use and maintain your vehicle. We ask that you carefully read the instructions and information provided as follows.

Please remember that the vehicle's life cycle depends on how you use and maintain it. Keeping it in perfect operating condition reduces the cost of repairs.

Please consider this manual an integral part of the vehicle. It must remain with its basic equipment, even in the event of a change in ownership.

For any issues, please see your **RIEJU** dealer, who will be delighted to serve you, or visit:  
**[www.riejumoto.es](http://www.riejumoto.es)**

Remember that for your vehicle to operate properly, you **MUST** always request original replacements.



## TABLE OF CONTENTS

Vehicle description .....	6	Ignition lock .....	30
Vehicle registration .....	7	Refuelling .....	32
Vehicle delivery (complete upon first delivery) .....	8	Adjusting the mirrors .....	33
Inspection prior to delivery (adjustments) .....	9	Adjusting the handlebar .....	34
Technical info .....	12	Handlebar components (left side) .....	35
Location of serial numbers .....	16	Handlebar components (right side) .....	39
Chassis identification number .....	16	Special warning when driving .....	43
Engine identification number .....	16	Safe riding .....	44
Main vehicle elements .....	18	Running-in .....	46
Instrument dashboard .....	21	Vehicle operation .....	48
Instrument settings .....	22	Pre-ride inspection .....	48
ABS .....	23	Starting .....	52
Mobile Bluetooth .....	23	Engine shutdown .....	53
Luminosity .....	24	inspection and maintenance .....	54
Interface .....	25	Daily inspection .....	54
Clock .....	26	Checking engine oil level .....	55
Information .....	26	Engine oil change .....	56
Language .....	27	Oil filter replacement .....	57
Units .....	27	Checking the coolant efrigerante .....	58
Maintenance .....	28	Coolant replacement .....	59
Fuel vapour control system .....	29	Checking the spark plug .....	60
Operation .....	30	Saddle .....	61
		Checking and replacing the air filter .....	62



Throttle cable adjustment .....	63	Vehicle storage .....	92
Throttle cable adjustment .....	64	How to reactivate the vehicle.....	94
Adjusting the clutch lever free play .....	65	Vehicle protection .....	95
Rear brake - adjusting pedal distance .....	67	Cleaning the vehicle .....	95
Side stand.....	68	Modifications and accessories.....	97
Grab handles .....	68	Warranty .....	98
Front suspension .....	69		
Brakes - Fluid.....	73		
Brakes - Pads .....	75		
Brakes - Bleeding the braking system .....	76		
Transmission chain (adjustment and tension) .....	77		
Adjusting the rear brake light switch .....	79		
Checking the battery .....	80		
Replacing fuses .....	82		
Inspecting tyre wear limit.....	83		
Tyre maintenance .....	84		
Silencer .....	85		
Tightening torque table.....	86		
Maintenance Schedule .....	87		
Introduction to electric start .....	89		
EFI injection system diagram.....	90		
EFI injection system operation and maintenance	91		
Vehicle storage and cleaning.....	92		



## VEHICLE DESCRIPTION

Equipped with a modern, robust and powerful 293 cc single-cylinder 4-stroke engine, liquid cooling, 33.5 hp, 27 Nm torque and a 6-speed gearbox with a slipper clutch, the RALLY 307 brings technology, lightness, and ergonomics together. It provides an accessible riding experience that is truly enjoyable and genuinely off-road.

With a high-resistance steel spine chassis, long-travel suspension, 21" and 18" wheels, and a large 7" vertical TFT display that boasts Mirror Link technology, this machine is ready to devour the kilometres. It has everything under control.

Passing rigorous tests under the most demanding conditions, the RALLY 307 has been tested by RIEJU's R&D team in the Touareg Legend Rally. This is an event that follows the original route and spirit of the Dakar Rally, with no assistance whatsoever. The RALLY 307 proved its robustness and reliability in one of the toughest environments in the world of rally raids.

With a dry weight of merely 137 kg, a seat height hardly 890 mm, and a 21-litre fuel tank, the new RALLY 307 is the perfect ally to conquer any terrain and to have adventures with no limits... with a Dakar-inspired style and RIEJU's unmistakable character.

Ø43 mm inverted fork and adjustable progressive rear shock absorber: maximum comfort and control on any surface, adapting to every rider's style and demands.

Ø300 mm front disc and Ø240 mm rear disc, with a fully disconnectable dual-channel ABS system: safety on the road and total freedom off-road.



## VEHICLE REGISTRATION

Please make a note of the chassis and engine serial numbers, which will help you for all purposes (certificate of characteristics, insurance, registration, etc.).

These numbers will be useful for you for any suggestions or complaints, as well as to order replacement parts.

Chassis serial number (p.16)

Engine serial number (p.16)

Dealer seal



## VEHICLE DELIVERY (complete upon first delivery)

- USER MANUAL  
Explain the importance of reading it and understanding all the information. Highlight the sections on safety and maintenance practises.
- WARRANTY REGISTRATION CARD  
Fill out all necessary information and provide a copy to the client.
- HANDLING  
Explain how to properly handle the vehicle.
- WARNINGS  
Explain the importance of the warnings to guarantee a long “life” for the vehicle.
- KEYS  
Deliver the complete set. Advise them to make a backup copy of the set.
- FIRST INSPECTION  
Explain that an inspection after 1,000 km is important.
- PERIODICAL MAINTENANCE  
Explain the need for periodical maintenance and state that failure to comply with guidelines for check-up and visiting the shop is grounds for “Loss of Vehicle Warranty.”



**INSPECTION PRIOR TO DELIVERY (ADJUSTMENTS)**

- General appearance** .....  .....
- Engine**
- Engine oil level .....  .....
- Chassis**
- No fuel leaks in: Tank output, fuel tap, and supply lines .....  .....
- Front and rear brake - Drain, if necessary .....  .....
- Coolant level, if applicable .....  .....
- Front, rear mudguard and attachment elements .....  .....
- Wiring of electrical installation around the steering column .....  .....
- Radii of front and rear wheels .....  .....
- Tyre pressure .....  .....
- Chain tension .....  .....
- Checking the equipment**
- Accelerator works and has free play. Adjust if necessary.....  .....
- Degrease both brake discs .....  .....
- Battery charged and terminals greased .....  .....
- Block steering or anti-theft block .....  .....
- Electric starter engine operation .....  .....
- General condition of front and rear suspension .....  .....
- Clutch cable properly adjusted .....  .....



- Operation of fuel cap closure .....  .....
- General inspection of nuts and screws: Callipers/discs, transmission/pinions, wheel nuts, tilt, engine mounts, exhaust system, shock absorber, gear selector, brake pedal/levers, manifold nuts, etc. ....  .....

**Fuel tank**

- Check that the tank is not in contact with the frame .....  .....

**Circulation components**

- The digital instrument dashboard checks itself when the ignition is turned on (depending on the model) .....  .....
- Adjustment of headlight height .....  .....
- Brake light by pressing the front brake lever and the rear brake pedal .....  .....
- Front, rear blinkers and mounting clips. ....  .....
- Horn operation .....  .....

**ON-ROAD TEST, at least 10 km**

- Engine and gearbox operation .....  .....
- Grip on road and suspensions .....  .....
- No abnormal sounds .....  .....

**AFTER ON-ROAD TEST**

- Coolant leaks .....  .....
- Fuel system, including hoses, clips, and all associated parts where leaks may appear .....  .....



CHECK FINAL APPEARANCE .....  .....

Date

Manufacturer signature



## TECHNICAL INFO

GENERAL INFORMATION	
Fuel	Unleaded petrol E5
Petrol tank capacity	21 litres
Fuel consumption	< 3.4 l/100 km
Kerb weight	153 Kg
Load capacity	190 kg (including driver)
Maximum permitted weight	343 Kg
Load on front axle	77 kg
Load on rear axle	76 kg
Braking deceleration	According to GB20073
Maximum climbable gradient	17° (> 30%)

DIMENSIONS	
Maximum length	2.180 mm
Maximum width	880 mm
Maximum height	1.405 mm
Distance between axles	1.460 mm



<b>CHASSIS</b>	
Front tyre	90/90-21
Rear tyre	120/80-18
Front brake	Ø300 disc
Rear brake	Ø240 disc

<b>ELECTRICAL SYSTEM</b>	
Fuses	25A, 15A, 10A
Headlamp	12V LED
Pilot/Brake light	12V 0.5/1.2W LED
Front position light	12V 2.6W LED
Front blinkers	12V 1.8W x 2 LED
Rear blinkers	12V 1.8W x 2 LED
Plate light	12V 0.5W LED
Battery	12V 6Ah
Ignition	ECU ignition control
Instrumentation	LCD screen



<b>ENGINE</b>	
Type	Single-cylinder 4-stroke, liquid-cooled
Diameter x Span	78 x 61.2 mm
Exact displacement	292 cc
Compression ratio	11:1
Maximum power	22.5 kW (31 CV) at 9,000 rpm
Maximum engine torque	26 Nm at 6,500 rpm
Idle speed	1,500 + 150 rpm
Spark plug	B8RC
Spark plug electrode gap	0.7 ~ 0.8 mm
Intake valve clearance	0.10 ~ 0.19 mm
Exhaust valve clearance	0.15 ~ 0.24 mm
Engine oil capacity	1.5 litres



Gearbox ratios	
1st gear	3,000
2nd gear	2,000
3rd gear	1,500
4th gear	1,250
5th gear	1,050
6th gear	0,905
Secondary transmission ratio	3,428
Primary transmission ratio	2,800



## LOCATION OF SERIAL NUMBERS

### Chassis identification number

This is the number (1) that is die-cut on the right of the steering tube.

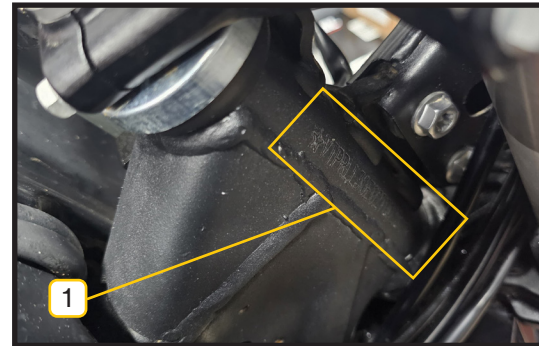

### Engine identification number

This is the number (1) that is marked on the top of the engine's left crankcase half.

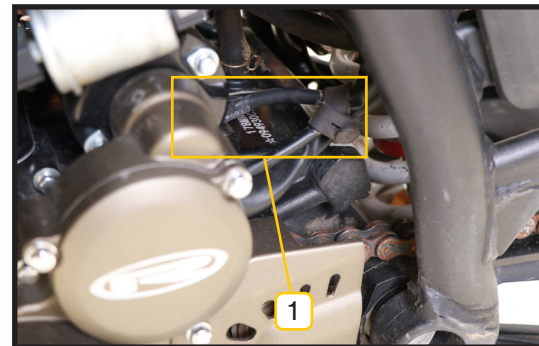



### Builder label

Your **RIEJU** has an identification plate (1) with details on: manufacturer, frame number, approval number, and sound emissions level. The frame number is also die-cut on the right side of the steering tube.

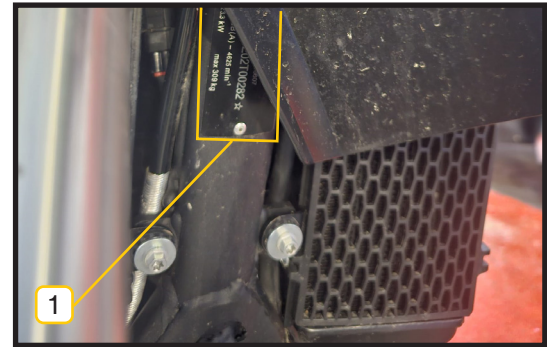



## MAIN VEHICLE ELEMENTS

1. Headlamp
2. Frame serial number
3. Tank
4. Seat lock
5. Rear blinker
6. Rear wheel
7. Side stand
8. Chain
9. Shock absorber
10. Engine model and serial number
11. Shift pedal
12. Horn
13. Front brake disc
14. Front wheel
15. Fork





1. Silencer
2. Seat
3. VIN frame number
4. Front blinker
5. Rear brake pedal
6. Passenger footpeg
7. Rear brake disc



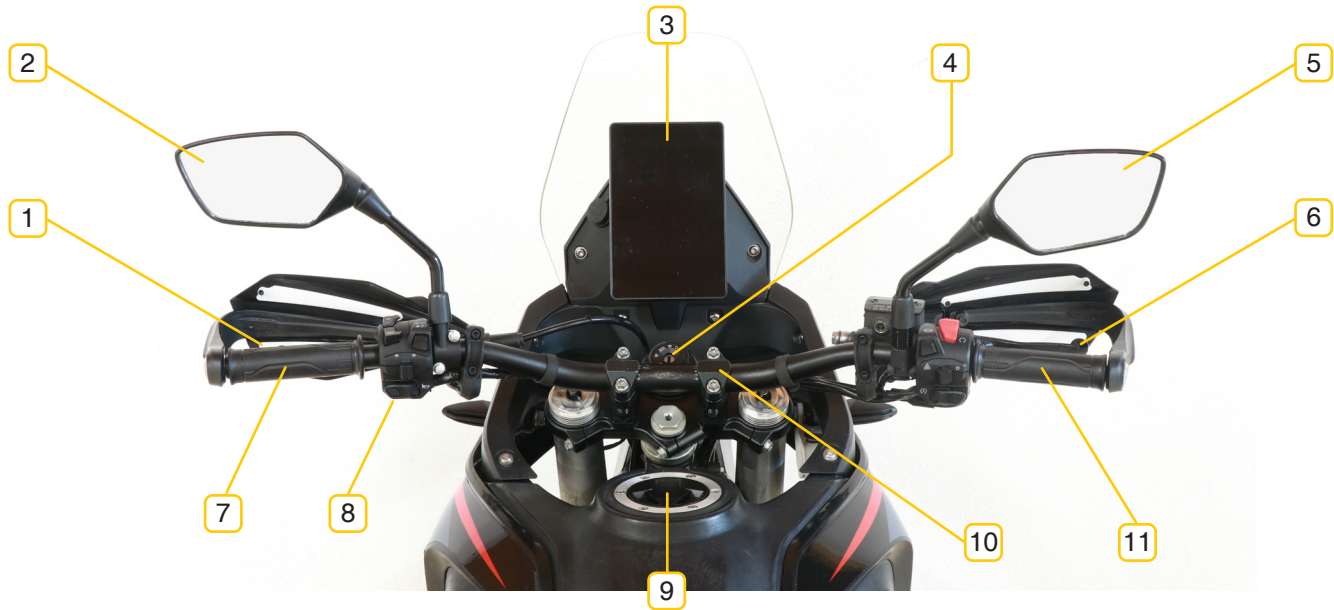

- 1. Clutch lever
- 2. Left rear-view mirror
- 3. Instrument dashboard
- 4. Ignition lock

- 5. Right rear-view mirror
- 6. Front brake lever
- 7. Left grip
- 8. Left handlebar switch cluster

- 9. Petrol tank cap
- 10. Handlebar mounting
- 11. Accelerator grip



## INSTRUMENT DASHBOARD

1. Time
2. Rpm x1000
3. Speed
4. Current gear
5. Total km
6. Environmental temperature
7. Engine temperature
8. Fuel level
9. Trip 1 and trip 2

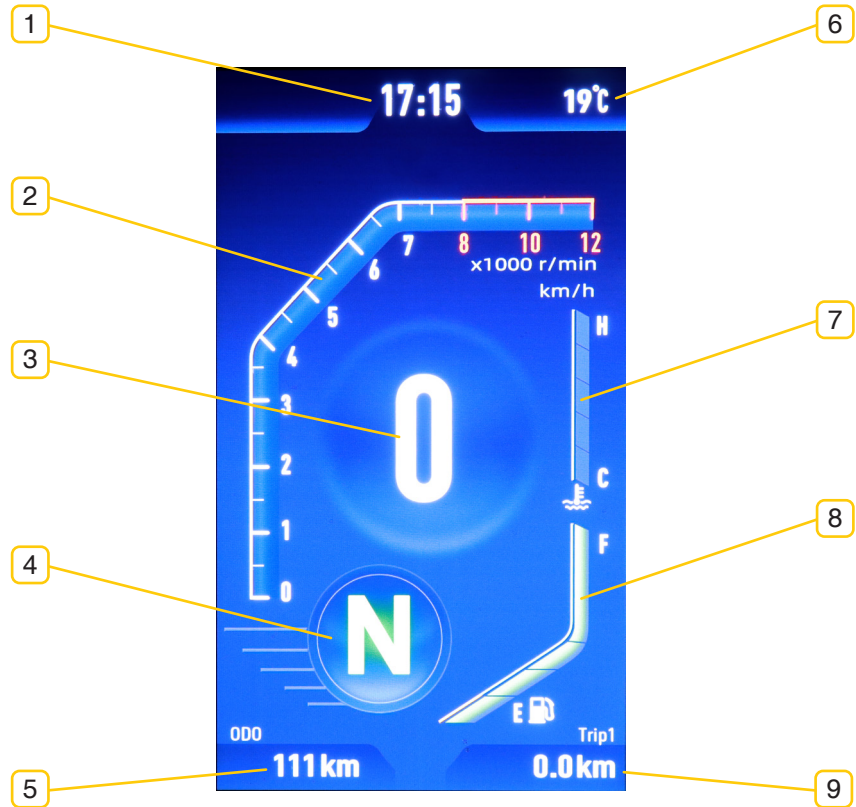



## Instrument settings

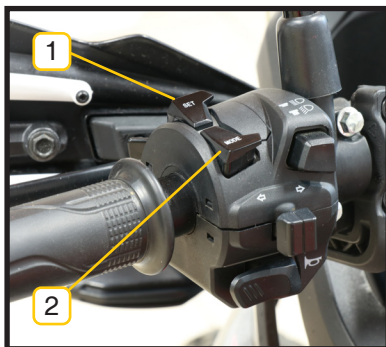

SET button:

Quickly click the SET button once to enter the bike's menu. Press the SET button for longer to open the Mirrorlink function.

Within the menu, use a quick click to select the currently highlighted option.

Within the menu, hold down the SET button to go back.

MODE button:

On the home screen, click quickly once on the MODE button to switch between Trip 1 and Trip 2, and press for longer to reset the currently selected trip to zero.

Within the menu, press MODE to scroll down through the menu options.





## ABS

To disconnect ABS: Select the ABS option using the SET button, then use SET again to choose the OFFROAD mode. The word OFFROAD will appear on the screen. Then press the ABS button (on the right switch cluster) for 3–4 seconds to deactivate the ABS. To reactivate it, follow the same steps, or simply turn the bike off with the key and the system will reset automatically.



## Mobile Bluetooth

2 simultaneous connections are enabled. For example, telephone and intercom.

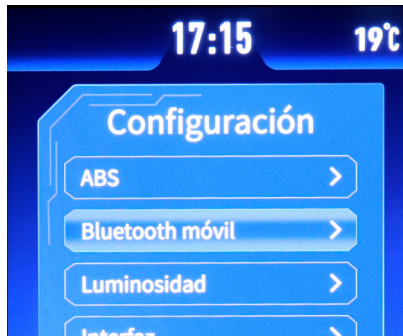



## Luminosity

Features 5 adjustable brightness levels plus an automatic mode.

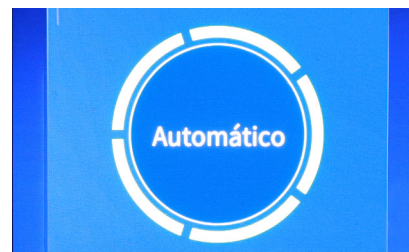
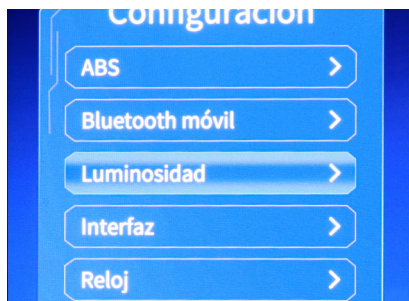



## Interface

Offers 2 modes (day/night), which can be selected manually or automatically.

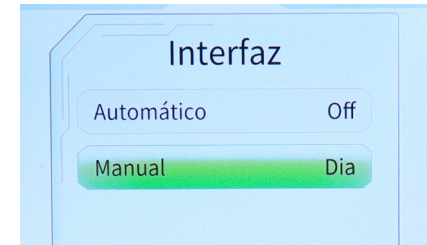
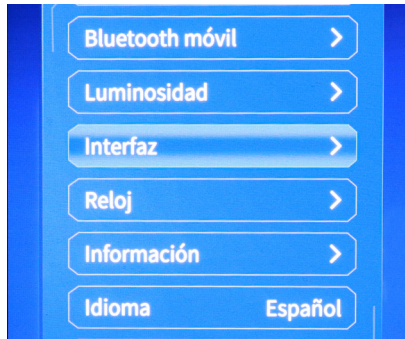



## Clock

Clock settings.

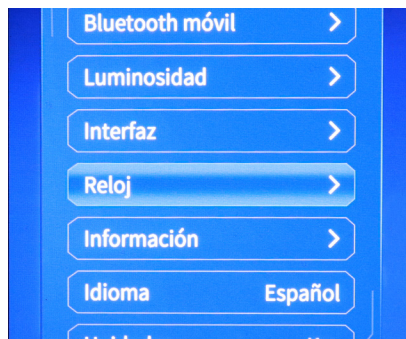

## Information

Software version.

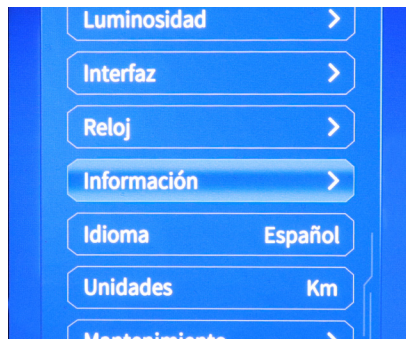



## Language

Select several different languages.



## Units

Distance unit selection.





## Maintenance

Maintenance interval.

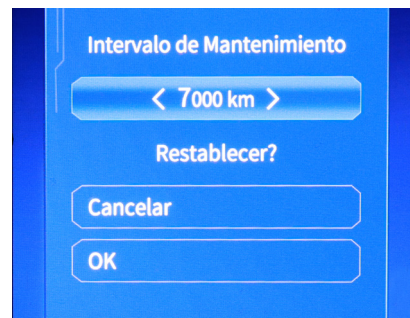



## Fuel vapour control system

The fuel vapour control system works as follows:

1. When the fuel in the tank is heated, petrol vapours evaporate and pass through a tank pipe by means of the rollover valve. They are then absorbed by the canister.
2. If the motorcycle tilts more than  $60^\circ$ , the rollover valve closes to prevent petrol from entering the canister.
3. Fresh air from the atmosphere enters through the canister inlet and then goes through the purge outlet, carrying the petrol vapours to the throttle body. This is where they mix with the injected fuel and enter the combustion chamber through the intake manifold to be burned.

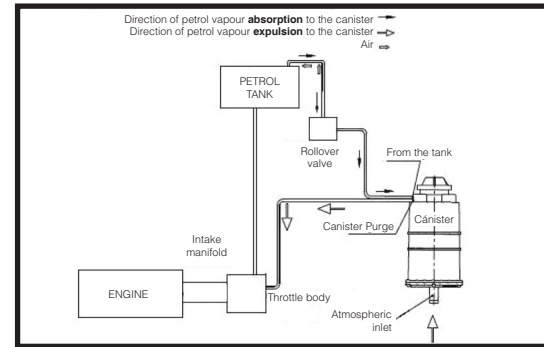



## OPERATION

### Ignition lock

The ignition switch of the vehicle is located on the front end of the fuel tank, beneath the instrument dashboard. The ignition switch and steering lock are integrated.

This vehicle comes with two keys, one of which should be kept safely as a spare backup.

The ignition switch lock, steering lock, seat lock, and fuel tank lock all use the same key. The ignition switch has three positions:

- The ignition circuit is connected, the engine can be started at any time, and all functional circuits of the vehicle are active. In this position, the key cannot be removed.
- ⊗ The ignition circuit is disconnected, and the engine cannot be started. In this position, the key can be removed.



Electric system connection.





Electric system disconnection.



Blocking steering and disconnecting the electric system.



This is the position to block the handlebar. First, turn the steering handlebar to the far-left position, press the key into the “” position, and then turn it counterclockwise to the “” position. In this position, the key can be removed, the ignition circuit is disconnected, and the engine cannot be started.



**CAUTION:** While this vehicle series is equipped with a side stand system, to ensure stability when parked, always attempt to turn the handlebars fully to the left instead of the right when locking the steering.

Do not turn the ignition key to the “” position while driving; otherwise, the motorcycle will lose control.



## Refuelling

To access the tank cap, please proceed as follows:

- 1 - Insert the key and turn it 1/2 rotation to the right.
- 2 - Open the cap toward the seat.
- 3 - To close it, keep the key turned to the right and press the cap down by hand into its position before returning the key to the central position.



**WARNING:** The fuel cap may feel a bit stiff, especially when the motorcycle is new. If you do not hear a click when you close it, this means it has not been properly secured, and fuel may leak.

### FUEL TYPE

Unleaded E5 petrol with an octane rating above 92 RON.

### TANK CAPACITY

21 litres

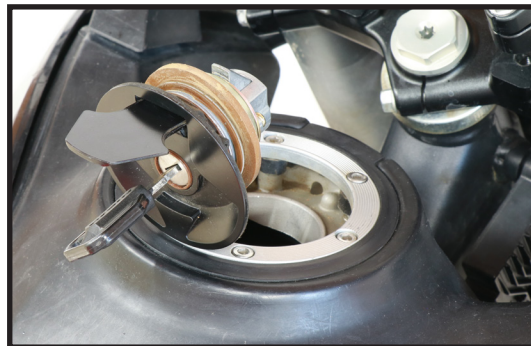



## Adjusting the mirrors

1. Adjust the mirror surface parallel to the handlebars.
2. Loosen the locknut with a 17 mm spanner. Leave a small gap between the locknut and the mirror stem thread.
3. Sit on the motorcycle and keep it upright. Adjust the mirrors to provide the widest possible rear view.
4. Once the adjustment is complete, tighten the mirror locknut again.

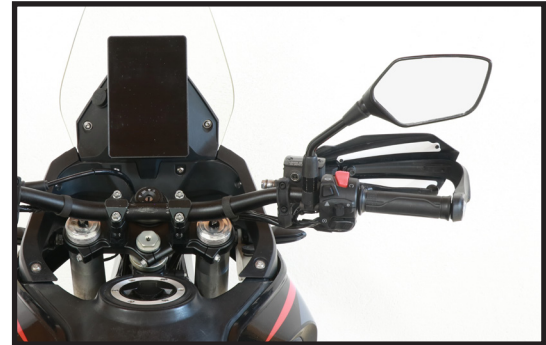



## Adjusting the handlebar

Correct handlebar adjustment depends on each rider's height and riding style.

1. Loosen the four handlebar mounting bolts by 90–180°, allowing enough flexibility to adjust to the desired position.
2. Sit on the motorcycle and move forwards and backwards. Then, turn from right to left until you find the ideal handlebar position. After this, tighten the four bolts.

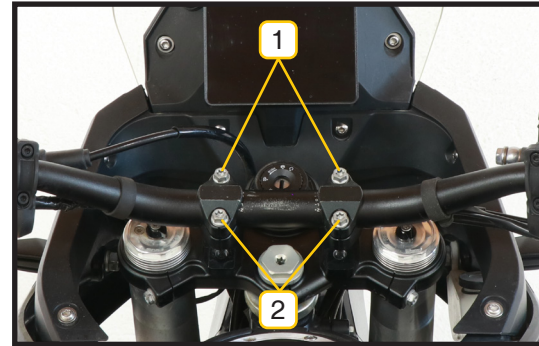

### CAUTION:

Tighten the two front bolts (1) first, then the two rear bolts (2).



## Handlebar components (left side)

### SET (1) button

Quickly click the SET button once to enter the bike's menu. Press the SET button for longer to open the Mirror-link function.

Within the menu, click quickly to select the currently highlighted option. Within the menu, hold down the SET button to go back.



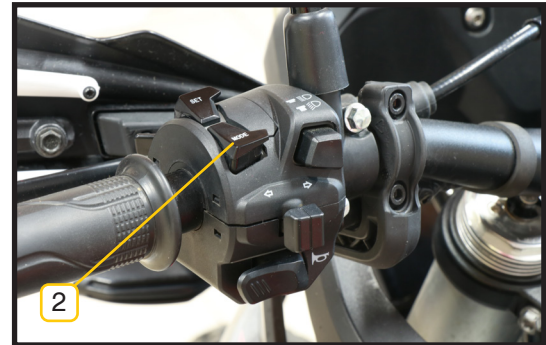

### MODE (2) button

On the home screen, click quickly once on the MODE button to switch between Trip 1 and Trip 2, and press for longer to reset the currently selected trip to zero. Within the menu, press MODE to scroll down through the menu options.





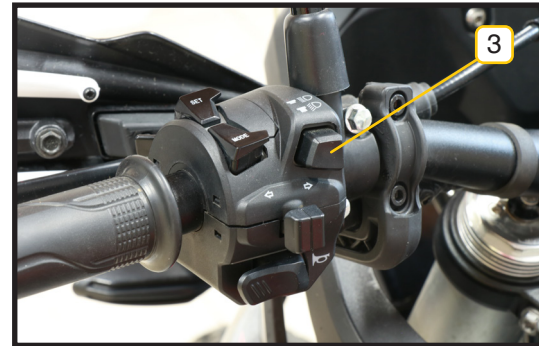

### Light switch (3)

When you press the high beam switch “”, the high beam lights turn on, and the high beam indicator “” on the instrument dashboard also lights up.



### Flash button (4)

When you press the button (1), the high beam light will turn on and the high beam indicator “” on the instrument dashboard will also light up. After releasing the button, the high beam will turn off and the indicator “” on the instrument dashboard will go out as well.

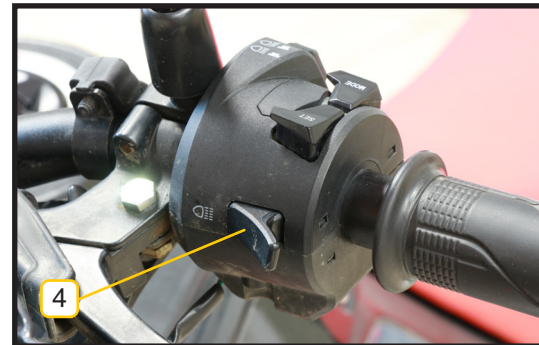





### Horn button (5)



When you press the “” button, the vehicle’s horn honks.





## Blinker switch (6)



When you press the blinker switch on the left handlebar to the left “”, the front and rear indicators on the left side of the motorcycle will flash simultaneously, and the turn signal indicator “” on the instrument dashboard will also light up and blink.

When the blinker switch on the left handlebar is pushed to the right “”, the front and rear right-hand blinkers of the vehicle will light up simultaneously, and the indicator warning light “” on the instrument dashboard will also illuminate and flash.

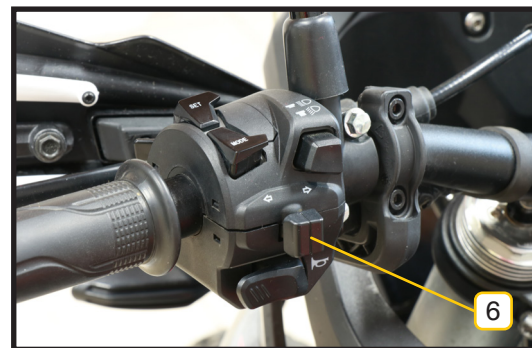
When the indicator switch on the left handlebar is pressed inward, the blinker lights are turned off, and the blinker warning light on the instrument dashboard will also go off at the same time.



### CAUTION:

- If one of the blinkers on either side of the vehicle is damaged, or if a blinker fails to light up for any other reason, the flashing frequency of the corresponding blinker (“” or “”) on the instrument dashboard will be faster than normal, which means you should check whether the blinker light on that side is faulty.



## Handlebar components (right side)

### ABS button - Deactivating

With the motorcycle stopped (0 km/h) and in neutral (N), press the SET-SET button and the OFFROAD icon will appear on the screen (see “Instrument Dashboard”).

Press the ABS button (2) for 3–4 seconds until the symbol appears.



### ABS button - Activating

To activate the ABS, press the SET-SET button for 3–4 seconds or turn off the motorcycle ignition.





**CAUTION:** While riding, it is strongly recommended not to deactivate the vehicle's ABS system to avoid accidents or personal injury. Deactivating the ABS on public roads is forbidden. This feature is intended for off-road use and for experienced riders only.







### Hazard switch (3)

When the “” switch is activated, all blinker lights and blinker indicators “” and “” on the instrument dashboard light up and flash simultaneously.

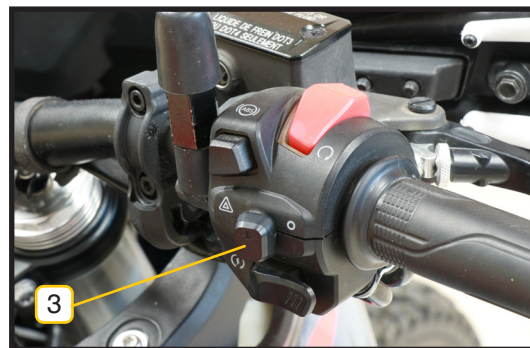
Please use the hazard lights to alert other vehicles in the event of an emergency stop, traffic accident, or vehicle breakdown.



### Electric start button (4)

The electric start button is located below the light switch. When the kill switch is in “” and the gear is in neutral, press this button to start the engine.



**CAUTION:** If you attempt to start the engine multiple times, do not hold the start button for more than 5 seconds. Excessive attempts overheat the starter motor. If the engine does not start after several attempts, check the power supply and starter circuit.





### Interruptor cortacorrientes de emergencia (5)

Cuando el motor se va a arrancar, el interruptor cortacorrientes está en “○”. En situaciones de emergencia, ponga el conmutador en “X”, se cortará directamente el encendido y el motor se parará.

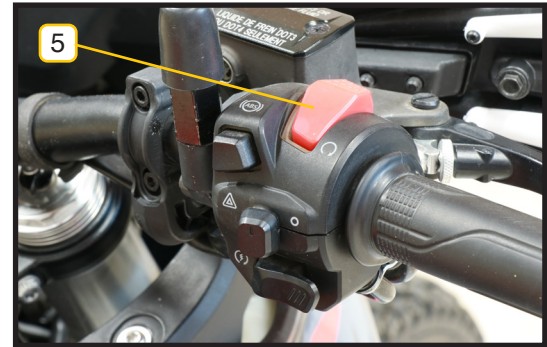



## Gear change

Warm up the engine to ensure normal operation.

1. When the engine on idle, operate the clutch lever and press down the gear lever to engage first gear.
2. Accelerate the engine and slowly release the clutch lever in a coordinated manner to start moving.
3. Once you have achieved balanced riding, decelerate, operate the clutch lever, move the gear lever up to engage second gear, and release the clutch lever again while accelerating all at the same time.
4. Follow this method for the remaining gears in the gear-box.

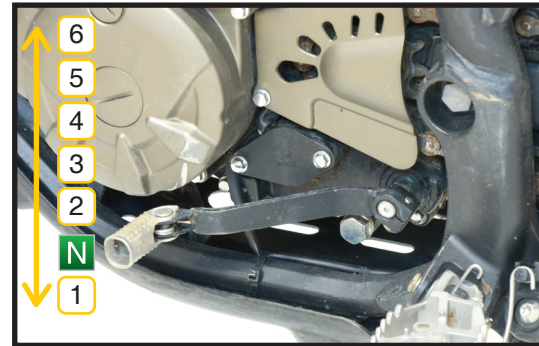



### Special warning when driving

1. Avoid running the engine at low revolutions (high gears) on motorways to prevent straining it in torque.
2. Avoid using the clutch in a partially disengaged state, as this causes wear on the friction discs.
3. If you feel a lack of power on steep inclines, shift down to a lower gear.
4. Do not rely solely on the front brake when descending in neutral at high speed.
5. To stop, release the throttle, operate the clutch, and brake. Use the engine brake.



#### **CAUTION:**

1. If you are riding at high speed, you will need a long distance to stop. Ride at an appropriate speed, allowing enough braking distance.
2. An inexperienced rider tends to use only the rear brake, which leads to rapid wear of the braking system and a longer stopping distance.
3. Use of only the front or rear brake is dangerous and can cause skidding or loss of control. Under wet conditions, on smooth surfaces or roundabouts, use extreme caution and apply the brakes gently. Sudden braking on smooth surfaces can result in loss of control over the motorcycle.



## Safe riding

### Before riding

1. Do not ride after taking medication or when not concentrated.
2. Inspect the motorcycle before starting your trip.
3. Wear a helmet and light-coloured, close-fitting clothing, along with any other protective body gear.
4. Do not drive if you feel unwell.
5. Do not ride under the influence or without a driving license.

### While riding

1. Ride smoothly, stay calm, and give your full attention to the road.
2. Maintain a steady speed and keep to the right-hand side.
3. Pay close attention at junctions. Proceed only when safe to do so.
4. Activate the blinkers before overtaking or changing lanes; complete the manoeuvre only after confirming it



is safe and maintain an appropriate distance from other vehicles and pedestrians.

5. Due to reduced visibility, reduce your speed when riding at night.
6. Do not brake unnecessarily or change lanes frequently.
7. To prevent accidents, avoid sudden braking or acceleration.
8. Reduce your speed before turning to prevent skidding.
9. When the road surface is wet after rain, braking distances are increased. Under such conditions, ride slowly and brake gently.
10. If you notice any irregularities while riding, stop the motorcycle and check them immediately.

### **When parking**

1. Turn the ignition to OFF and lock steering.
2. Park in a stable area with the side stand.
3. Check for fuel, oil, or coolant leaks.
4. Keep the motorcycle away from fire and do not smoke near it.



## **RUNNING-IN**

### **Engine operation**

Whether hot or cold, the engine should have sufficient idling time before starting to ensure that the oil circulates to all lubricated parts.

During the running-in, the engine speed must not exceed 5,000 r/min for the first 500 km, and must not exceed 7,000 r/min between 500 and 1,000 km.

Throughout the running-in, both gear and engine speed should be changed frequently, and the motorcycle should not be ridden continuously for long periods at a fixed gear and speed.

When the engine operates for a prolonged time at a constant low speed during the running-in period, component wear increases. As such, do not ride at a steady low speed for long periods.

During running-in, avoid sudden acceleration and braking except in emergencies.

Do not drive while dragging the gear. Anticipate deceleration in advance and keep the engine running smoothly at all times.

Avoid long-distance riding during the running-in period to allow the engine enough time to rest.



The running-in period has a major influence on the vehicle's service life and fuel consumption, so read the manual carefully before use. (During the first 500 km, correct vehicle operation will ensure performance so you can enjoy your riding experience.)

### **Tyre running-in**

The new tyre's surface is smooth. Riding at high speed can easily lead to dangerous situations. For maximum tyre grip, the running-in process is essential.

During the first 200 km, you may run in the tyres by taking corners at low speed until all edges of the tread are fully worn in.

A raised area on the tyre tread poses an accident risk. The way to prevent such bulging is through proper tyre running-in.

### **Brake system running-in**

During the initial 500 km, the new brake discs remain in their original state, so they have not yet reached their optimal friction level. To compensate reduced braking efficiency, apply slightly greater pressure to the brake lever.



#### **CAUTION:**

- When running a new vehicle, you must vary the engine speed from time to time. Do not ride continuously at a fixed speed. The purpose is to subject the components to stress so they can fully adapt, but without applying excessive load.



## VEHICLE OPERATION

### Pre-ride inspection

If you do not inspect the vehicle before riding, the likelihood of accidents and damage increases. Pay attention to the following elements:

#### Steering system

- The handlebar turns smoothly without sticking.
- The steering column does not move or feel loose.

#### Throttle

- The throttle cable has the correct amount of free play.
- The throttle operates smoothly without sticking.

**Brake**

- The brake lever and brake pedal operate normally.
- The brake fluid level is correct in the brake fluid tank.
- You can clearly feel the pressure point when braking.
- The brake disc and friction pads must be free from water and oil stains.

**Shock absorber**

- Press to ensure it returns smoothly.

**Transmission chain**

- There is no excessive wear or damage.
- The chain tension is correct.



### **Tyre**

- The tyre pressure is correct.
  
- The tread depth is not excessively worn.
  
- The tread surface is free from cracks or cuts.

### **Engine oil**

- The oil level is correct.

### **Cooling system**

- The coolant level is correct.
  
- There are no coolant leaks.

### **Lighting**

- Dipped beam / front position light, taillight / brake light, blinkers, headlamp, and instrument illumination all function normally.



### **Light indicators**

- The high beam, neutral, and blinker indicators controlled by the brake lever switch operate correctly. The oil pressure warning lamp, engine malfunction indicator lamp, water temperature warning lamp, and oil level warning lamp do not flash or illuminate after the engine is started.

### **Horn**

- Operates correctly.

### **Engine kill switc**

- Operates correctly.

### **Side stand**

- Can be retracted and deployed normally.

### **Rear-view mirrors**

- With the vehicle in vertical position, objects located within 10 m behind and 4 m to the sides should be clearly visible in both rear-view mirrors.
- If not, adjust the mirror angles accordingly.



## Starting

Check that there is sufficient fuel in the tank.

1. Insert the ignition key into the lock and turn it to position (1) "O".
2. Set the kill switch (1) to the ON position "O".
3. Ensure the gear is in neutral and that the corresponding indicator is illuminated.
4. Twist the throttle 1/8–1/4 turn.
5. Press the start button.
6. Slightly open the throttle to raise the engine speed and allow the engine to warm up.



**CAUTION:** If you attempt to start the engine multiple times, do not hold the start button for more than 5 seconds. Excessive attempts overheat the starter motor. If the engine does not start after several attempts, check the power supply and starter circuit.



**CAUTION:** Do not start the engine without first ensuring the gear is in neutral, or you may cause an accident.

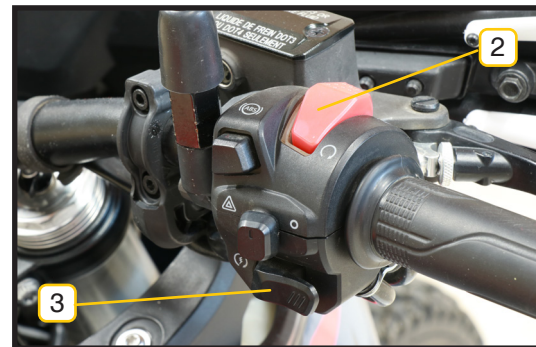
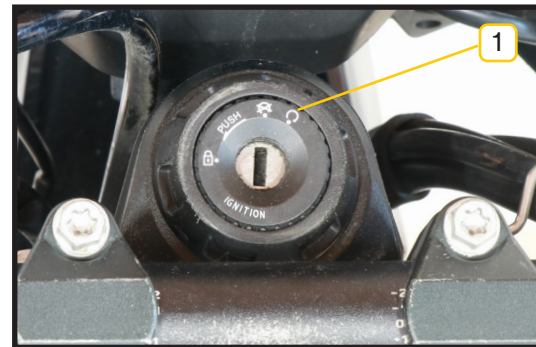



## Engine shutdown

1. Release the throttle and reduce the engine speed.
2. Place the gear in neutral.
3. Set the kill switch (1) to the OFF position.





## INSPECTION AND MAINTENANCE

### Daily inspection

After using the vehicle under adverse conditions, after rain, or after washing the vehicle, you must properly lubricate. To ride safely, you must maintain good lubrication of moving parts, which is necessary to prolong the service life of the vehicle.

Daily inspection and lubrication points include:

- Clutch lever.
- Brake lever.
- Brake pedal bearing.
- Side stand shaft and side stand spring hook.
- Main and passenger footrest shafts and return springs.
- Transmission chain.



### CAUTION:

- Except for the transmission chain, which requires chain oil, it is recommended to lubricate other points with coloured lithium grease



## Checking engine oil level

Check the engine oil level before starting.

Keep the motorcycle in vertical position on a level surface and check the level through the sight glass on the lower right side of the engine.

The level should be between the upper mark (1) and lower mark (2).

If the level exceeds mark (1), drain the excess oil. If it is below mark (2), add more engine oil. Use a high-quality, suitable multigrade oil.

Recommended oil: GRO SMART OIL SAE 10W40, or suitable alternatives according to the chart on the right.

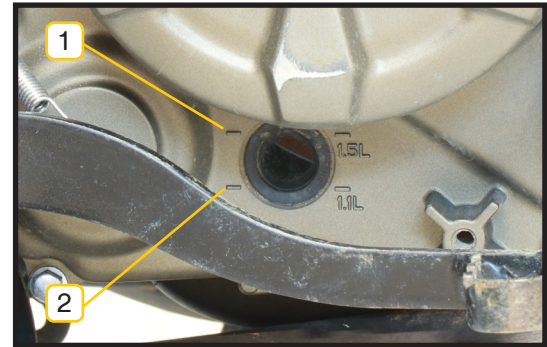



## Engine oil change

Engine oil is very important for the engine, so you must check it periodically. After the first 1,000 km, change the engine oil. After this initial change, replace it every 5,000 km, checking the level every 1,000 km and topping up if necessary.

Remove the drain screw (1) and empty the oil into a suitable container when the engine is warm.

Clean the oil filter screen and then put it back in place with the drain screw.

Pour 1.2 litres of new engine oil through the filler hole (2), start the engine, and let it idle for 2–3 minutes.

After stopping the engine and letting it sit for 1–2 minutes, check through the sight glass that the engine oil level is between the upper and lower marks with the motorcycle in vertical position.

To avoid mechanical failure, do not mix different brands or grades of oil.

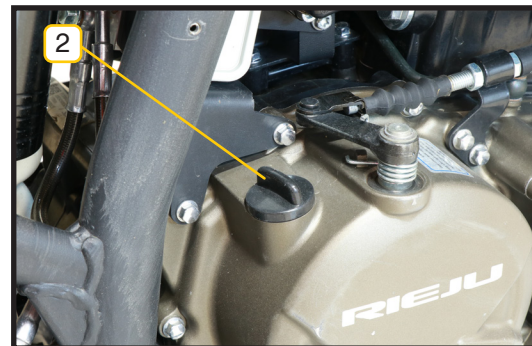
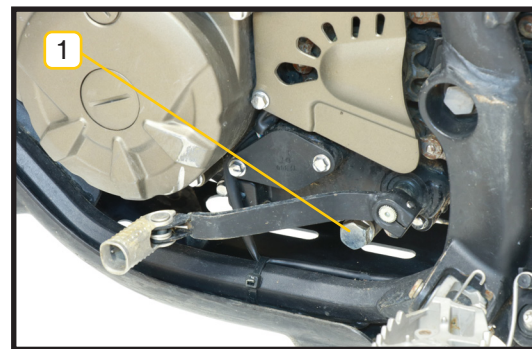



## Oil filter replacement

Whenever you change the engine oil, you must also change the oil filter.

Remove the oil filter cover and take out the old filter.

Fit a new oil filter and replace the cover.

Also clean the oil filter screen. After reassembling, fill the engine with 1.4 litres of new oil.

Start the engine and let it idle for 2–3 minutes.

Stop the engine for 1–2 minutes and check that the engine oil level is between the upper and lower marks, keeping the motorcycle vertical on a flat surface.

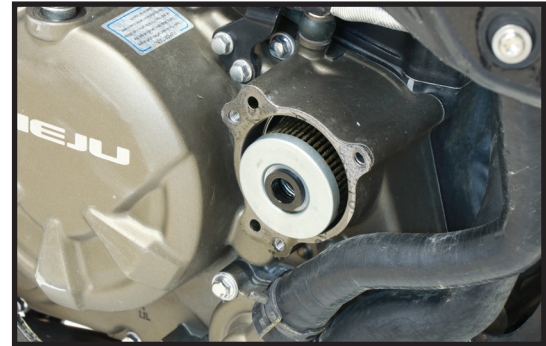



## Checking the coolant efrigerante

Check the coolant before riding.

Keep the motorcycle vertical on a flat surface and retract the side stand.

Use the expansion tank to check that the coolant level is between the upper and lower marks.

If the level is above the upper mark, drain the excess coolant.

If the level is below the lower mark, add coolant until it exceeds that level.





## Coolant replacement

You must use a coolant with G40 specifications.

When changing the coolant, first remove the radiator cap (1), then remove the coolant drain screw (2) on the bottom of the engine to ensure the coolant is completely drained.

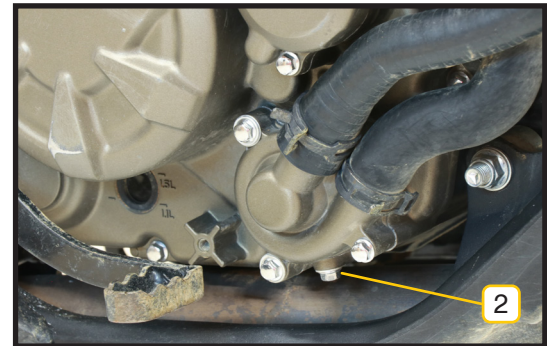
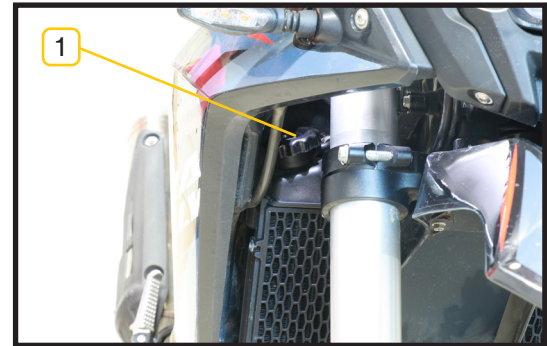

### CAUTION:

Do not check or remove the cap when the engine is hot.



## Checking the spark plug

1. Remove the spark plug cap, clean the area around the spark plug, and unscrew it using a spark plug spanner.
2. If the spark plug has corroded or has heavy carbon deposits, replace it.
3. Adjust the spark plug electrode gap to between 0.7–0.8 mm.
4. Use spark plugs with the recommended heat range.



**TIP:** Before assembling any spark plug, measure the separation between electrodes with a feeler gauge and adjust according to specifications.



**CAUTION:** When installing the spark plug, always clean the surface of the washer housing to prevent debris from entering the combustion chamber. Screw the spark plug in by hand, gently along the threads, and finish by tightening with a suitable wrench.

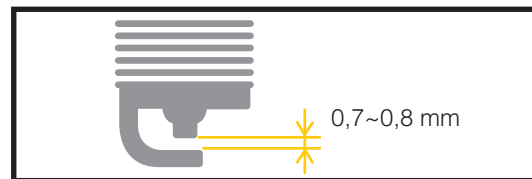

### SPARK PLUG TYPE

B8RC

### SEPARATION BETWEEN ELECTRODES

0,7~0,8 mm



## Saddle

### To remove the saddle:

1. Insert the key into the lock (1) located on the left side beneath the saddle.
2. Turn the key to unlock it.
3. Remove the saddle by pulling backward.



### To install the saddle:

1. Position the saddle.
2. Fit the tabs (A) into the mounts (B) so that it is firmly held.
3. Slide the saddle forward until in position.
4. Press down on the rear of the saddle to lock it (4).
5. Remove the key from the lock.

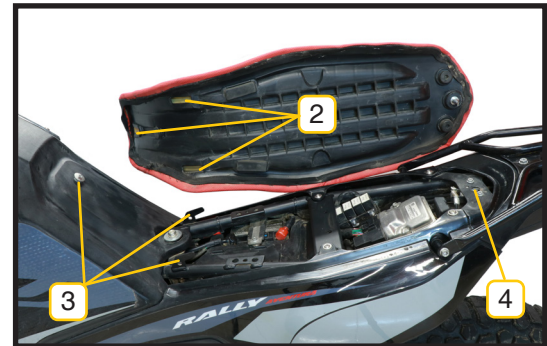



## Checking and replacing the air filter

Remove the filter element to check if it is dirty.

1. Remove the saddle (see section).
2. Press the two tabs (1) and remove the filter cover.
3. Pull the filter upwards to remove it. If you find dust or dirt, you must replace the air filter element.
4. Reassemble following the reverse order.

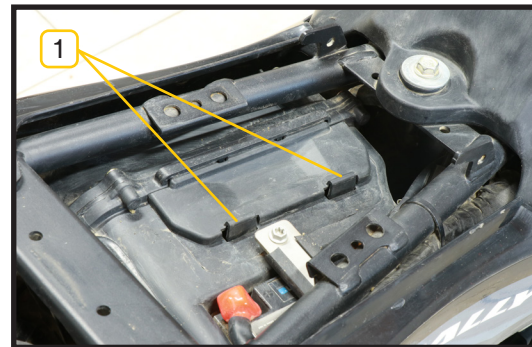

**CAUTION:** You must correctly install the filter element to prevent impurities from entering the engine, which could shorten its lifespan. Furthermore, do not allow water to enter. If you ride in dusty areas, replace the filter element more frequently than indicated in the Maintenance Schedule. Check for cracks in the filter element and replace it if any are found. The drain tube in the air filter box collects water and oil that do not return to the engine. You must empty it periodically.

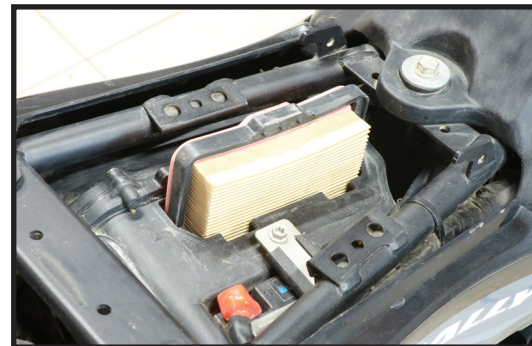



## Throttle cable adjustment

1. Check that the throttle operates smoothly.
2. If you need to adjust it, remove the protective cover (1).
3. Turn the cable adjuster (2), loosening the locknut (3) first.
4. Check that the throttle free play is 2–6 mm by adjusting the cable tension.
5. Tighten the locknut (3) to secure adjustment.



**CAUTION:** After adjusting the throttle free play, check the throttle movement. Do not increase the idle speed with the free play adjustment. The throttle must return automatically to its initial position when released.

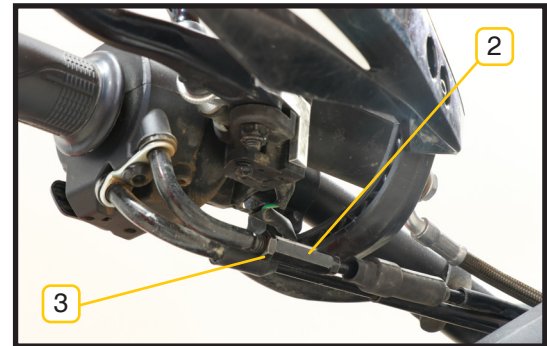
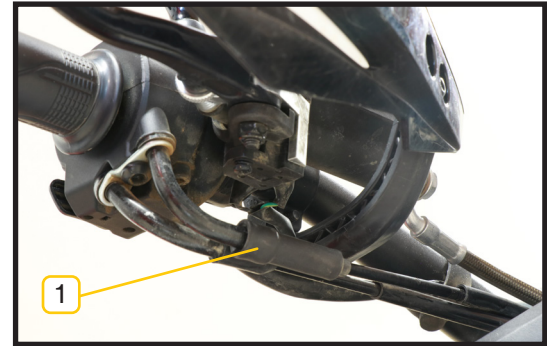



## Throttle cable adjustment

1. Throttle valve.
2. The EFI system automatically regulates adjustment of idle speed with the injection system. Therefore, the idle speed need not be adjusted manually.

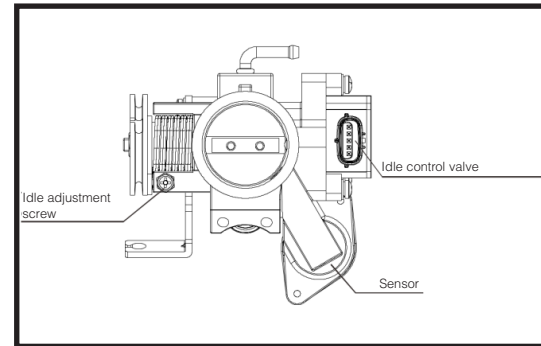



## Adjusting the clutch lever free play

### Adjustment on the upper end.

Measure the clutch lever free play at the tip of the lever and the grip.

#### CLUTCH LEVER FREE PLAY

10-20mm.

If adjustment is necessary:

1. Slide back the protective cover (1)
2. Loosen the lock wheel (2).
3. Move the wheel to adjust the clutch (3).
4. With the wheel, set the position (2).
5. Place the protective rubber cover (1).

If further adjustment is needed, operate the adjuster located at the other end of the cable on the engine.

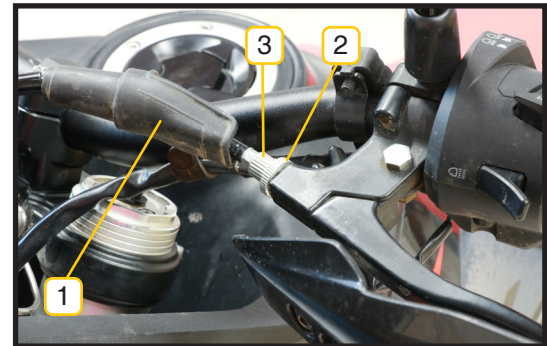
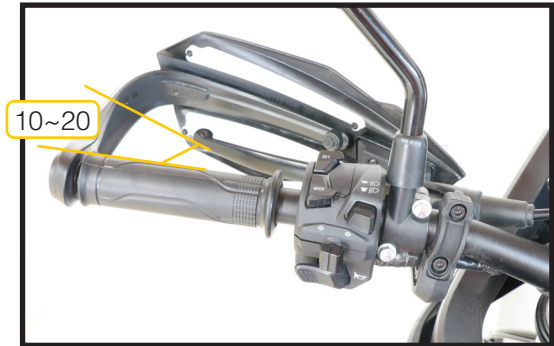



### Adjustment on the lower end.

1. Loosen the locknut (1).
2. Adjust the cable tension using the adjuster nut (2).
3. Set the position with the nut (1).

After adjustment, start the engine and check clutch operation. If the clutch slips or it is difficult to engage the gear, readjust.

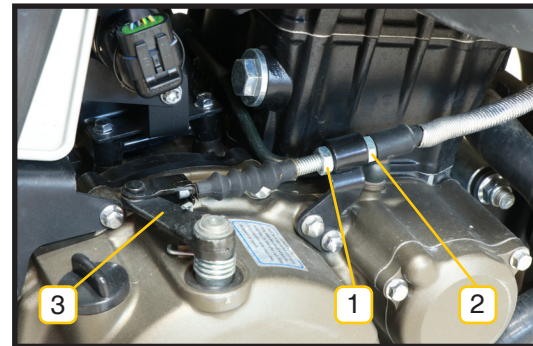



## Rear brake - adjusting pedal distance

When the brake pedal is in resting position, it should have 10-15 mm play.

To adjust the position, please follow the steps below:

- 1 - Loosen the locknut (1).
- 2 - Move the adjustment rod to adjust the pedal (2).
- 3 - Check that the brake responds correctly and does not drag.
- 4 - Secure the position with the locknut (1).

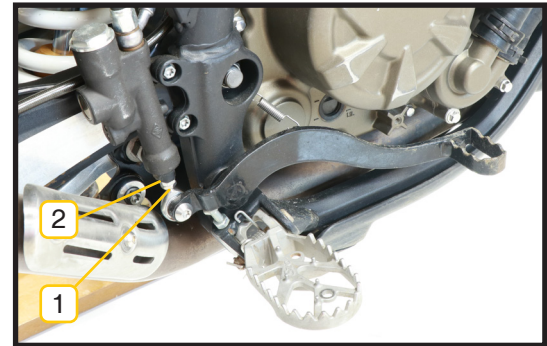

**CAUTION:** After adjustment, check that the brake light comes on when you press the pedal.



## Side stand

This model is only equipped with a side stand.

It includes a safety switch that prevents the engine from starting or running if the stand is extended while a gear is engaged.



## Grab handles

Both sides of the passenger seat have side grab handles. If you wish to add a luggage rack, do not exceed a 5-kg load.





## Front suspension

COMPRESSION (L - left)	REBOUND (R - right)
21 clicks from CLOSED	18 clicks from CLOSED

1. Air bleed screw: Releases excess pressure. Loosen it when the motorcycle is on a stand with both wheels off the ground.

2. Manually turn the black adjustment knob (clockwise) until it can turn no further. Then, open it step-by-step (click-by-click) until you reach the desired adjustment.

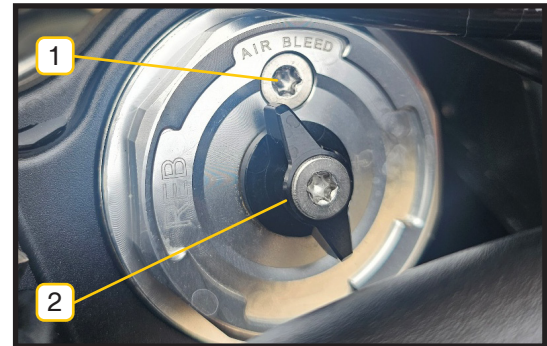
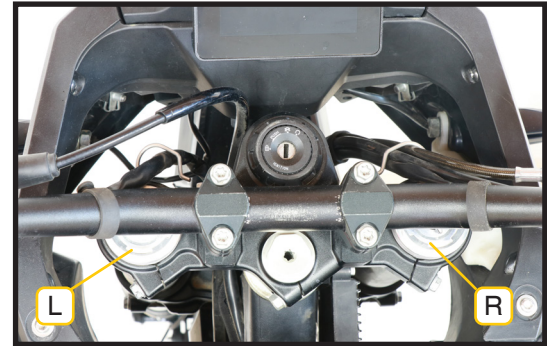



This is the recommended height for the front suspension adjustment: 6 mm above the upper clamps.

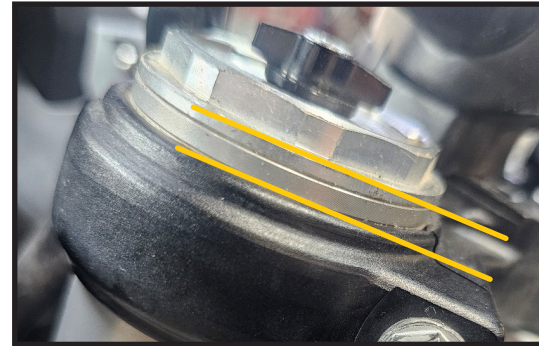

1. To obtain a greater feeling of stability and increase the front height, you can reduce adjustment to 2 mm.

2. To achieve a more agile feeling and reduce the height, you may increase adjustment by up to 15 mm.

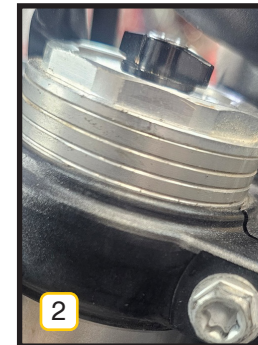
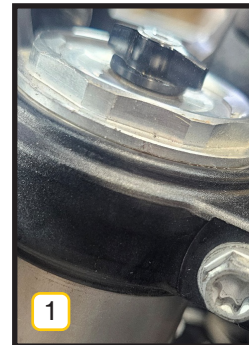



## Rear suspension

COMPRESSION (1) (top screw)	REBOUND (2) (lower screw)
16 clicks from CLOSED	2 clicks from CLOSED





Use the double adjustment nut for preload adjustment. Recommended distance is 23 mm. It is not recommended to increase or reduce more than three full turns from the indicated distance.

Increase the distance to raise the height of the motorcycle and provide a firmer feel.

Reduce the distance to lower the height of the motorcycle and provide a softer feel.

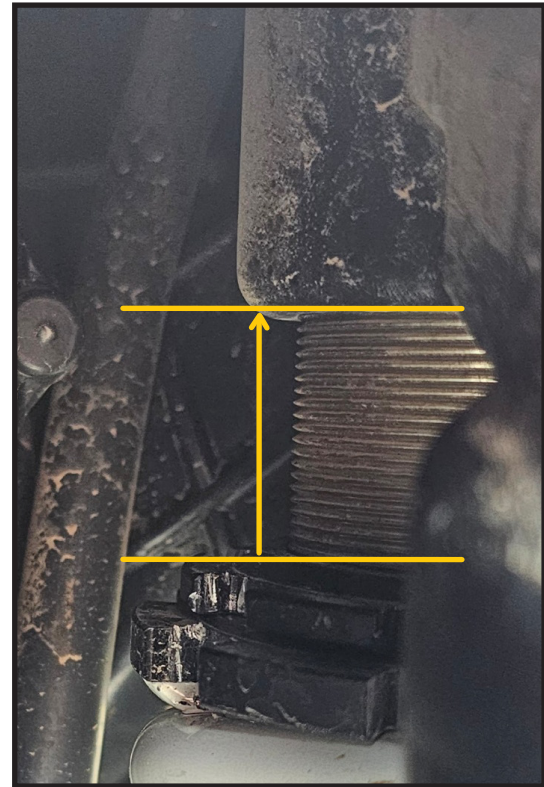



## Brakes - Fluid

Check whether the brake fluid level is above the mark through the sight glass (1).

If the level is below the lower level mark, you must add brake fluid until it exceeds this mark by 3–5 mm. In this case, also check whether the wear on the brake pads is within limits.

To change the brake fluid, completely drain the used brake fluid as follows:

1. Keep the brake pump horizontal (it is not necessary to remove it from the handlebar), then open the cover and remove its gasket.
2. Remove the brake calliper and place the bleeding valve in the lowest position.
3. Loosen the bleeding valve and allow the brake fluid to drain into a container.
4. When the brake fluid has been removed, pour in 30–50 ml of new brake fluid and allow the old fluid to drain out.
5. Tighten the bleeding valve, clean the calliper of any remaining brake fluid, and then install the calliper back

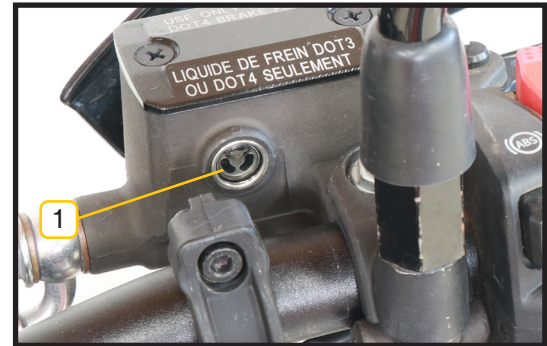



onto the motorcycle.

Next, add new brake fluid to the brake pump and follow these steps:

1. Connect a transparent tube to the bleeding valve (secure it tightly) and loosen the valve by 120°.
2. Add brake fluid to the pump and let it drain through the bleeding valve (without pulling the brake lever) until the fluid flows without bubbles. Tighten the valve again.
3. Operate the lever several times and repeat the previous step (b) until the lever feels firm. Finally, fit the cover and gasket on the brake pump and tighten the screws.



**TIP:**

- Use DOT4 brake fluid from a sealed container.
- Do not mix different types or brands of brake fluid.
- Do not use contaminated brake fluid.



**CAUTION:** Do not drink or allow brake fluid to splash into the eyes. It is harmful. If brake fluid is swallowed, induce vomiting. If splashed in the eyes or on the skin, wash the affected area thoroughly with plenty of water.



## Brakes - Pads

1. Visually inspect the wear on the brake pads at the intervals indicated in the maintenance schedule. When checking, follow the direction of the double arrow (3). If the wear limit line (4) of the pads has been reached, replace both pads at the same time.
2. Check that there are no brake fluid leaks in the braking system. Also check that the brake hoses are not cracked or deformed.



### CAUTION:

- Use only original Rieju spare parts. For any repair or maintenance of the braking system, please contact your authorised Rieju dealer.
- Exercise caution when using new brake pads. Operate the brake lever or pedal several times at low speed until the pads regain normal braking force.





## Brakes - Bleeding the braking system

Bleeding the pump:

1. The brake pump on the right side of the handlebar requires the front wheel to be rotated (in the opposite direction of travel).
2. Open the cover with its gasket and repeatedly operate the lever until bubbles stop appearing.

If the lever feels soft, bleed the air from the brake calliper.



Bleeding from the calliper:

1. Tightly connect a transparent tube to the bleeding valve and firmly operate the brake lever while loosening the bleeding valve by 90°.
2. Drain the brake fluid for 1–2 seconds and then tighten the bleeding valve again.
3. Release the front brake lever. Repeat the previous steps until the lever feels firm.



**CAUTION:**

When bleeding the calliper, add brake fluid to the pump while keeping the level high. Do not expose the brake fluid to air for too long.

**CAUTION:**

The disc brake system provides high braking pressure. For your safety, replace the brake fluid every 2 years.

**Transmission chain (adjustment and tension)**

The chain must be adjusted to have 30 to 40 mm tolerance at the midpoint between the drive and rear sprockets.

To adjust the proper tension, you must conduct these steps on both sides of the wheel equally:

- 1- Put the gearshift box in neutral and loosen the nut and axle (1) of the rear wheel.
- 2- Loosen the locknut (3)
- 3- With the screws (2), adjust the chain's tension, ma-





king sure that there is always the same distance on both sides of the axle. To this end, use the reference marks (4) on the swingarm.

4- Lock the position with the 2 nuts (3) and tighten the nut that secures the rear wheel axle.

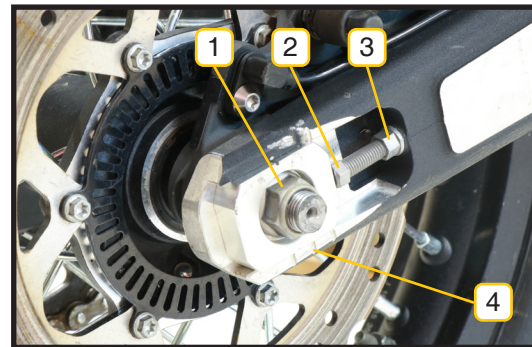

**TIP:** The chain must be kept perfectly clean and adequately lubricated every week.



**CAUTION:**

A chain that is too loose can cause an accident as well as mechanical damage.

The chain must be replaced if it has been corroded by battery electrolyte or any other corrosive liquid.



## Adjusting the rear brake light switch

After checking the operation of the rear brake, verify that the brake light illuminates when you press the brake pedal. If it does not light up, adjust the nut (1).

If the brake light still does not light up, check the LEDs of the rear light, the circuit, and the brake light switch.

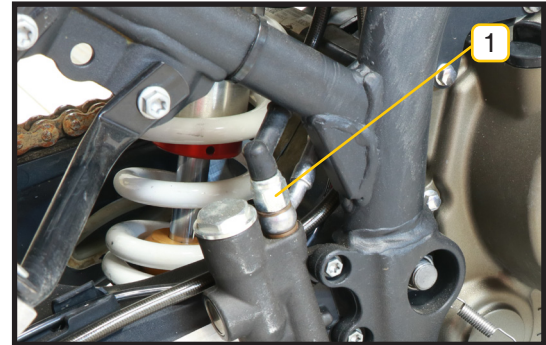

### CAUTION:

Before adjusting the brake light switch, make sure that the brake pedal has correct free play.



## Checking the battery

1. Remove the saddle (see section).
2. Remove the three lower screws (1) from the side panel.
3. Remove the two upper screws (2) from the side panel.
4. Remove the front screw (3) from the side panel.
5. Carefully pull on the front part of the cover to access the battery.
6. Clean the dirt and any corrosive impurities from the surface of the battery.
7. Check the guide line connection. Replace if corroded.

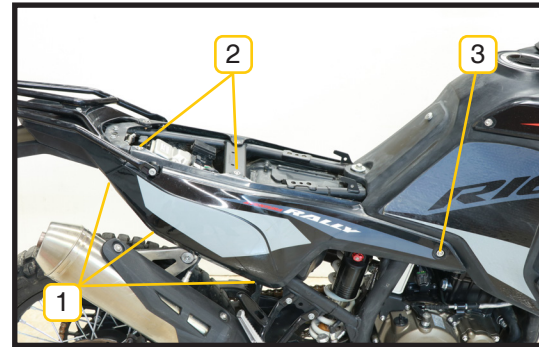



To remove the battery:

1. Remove the screw (4) from the battery bracket.
2. Take the battery out.



**CAUTION:**

1. When you remove the battery, first disconnect the negative (-) terminal and then the positive (+). When you reinstall the battery, connect the positive (+) terminal first and then the negative (-).
2. This battery does not require electrolyte maintenance.
3. The battery contains sulphuric acid, which can cause severe damage if it contacts the eyes or skin. If this occurs, wash with plenty of water for 5 minutes and then seek medical assistance.
4. Do not allow impurities to enter the battery compartment.



**CAUTION:**

Do not wash the battery area with water.



## Replacing fuses

1. Remove the saddle (see section).
2. Open the fuse box cover (1).
3. Remove the blown fuse and replace it with a new one.
4. If the new fuse blows again, this indicates a fault in the electrical circuit.

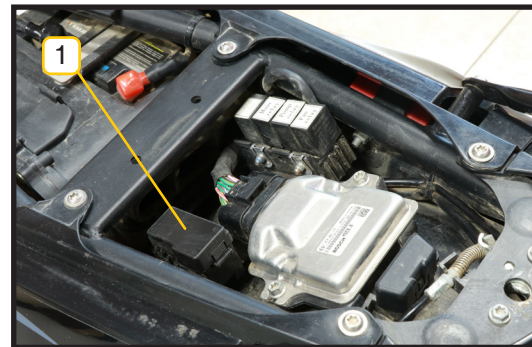

### CAUTION:

Do not replace the fuse with one of a different amperage, nor use wire as a substitute. This may cause serious damage to the electrical system or even start a fire in your motorcycle.



### CAUTION:

- If the fuse burns out frequently in a short period of time, this indicates a fault in the electrical system. Please immediately contact an authorised **RIEJU** dealer.





## Inspecting tyre wear limit

Check the tread depth of both tyres regularly. For your own safety and to extend tyre life, it is recommended that you frequently perform this inspection.

Front tyre	90/90-21
Rear tyre	120/80-18



### CAUTION:

- Excessively worn tyres may puncture and cause you to lose control of the vehicle.
- When the tyre tread reaches the minimum permitted depth, handling and grip will be significantly reduced.



## Tyre maintenance

Abnormal tyre pressure will shorten tyre lifespan.

Low tyre pressure will make steering difficult and worsen tyre wear.

Excessively high tyre pressure will reduce the contact area between the tyre and the ground. This makes the vehicle prone to slipping and losing control.

At high speeds, the tyre valve tends to open due to centrifugal force. To prevent a sudden air leak, a rubber cover with a metal-coated core is installed on the valve with a threaded connection.

Tyre inflation pressure is directly proportional to tyre temperature. As such, tyre pressure should only be adjusted when cold, when the tyre temperature is roughly the same as the ambient temperature.

At ambient temperature, check tyre pressure according to the following table:

Front tyre	225 kPa
Rear tyre	225 kPa



### CAUTION:

- Abnormal tyre pressure will affect vehicle handling and may cause an accident.
- Overloading may cause tyre failure and loss of vehicle control.
- Check tyre pressure at least once per month.



## Silencer

The exhaust silencer incorporates a catalytic converter. As such, do not allow foreign substances such as oil, petrol, acids, or salt to enter it, as they will render the catalyst ineffective.





## Tightening torque table

COMPONENT	Tightening torque (Nm)
Engine fasteners	M8x1.25: (18±2,7) M10x1.25: (45±4,5)
Fork joints	M8x1.25: (18±2,7) M14x1.5: (75±7,5)
Front disc	M8x1.25: (35±3,5)
Rear wheel axle	M14x1.5: (75±7,5)
Steering axle	M22x1: (50±5) M25x1: (60±6)
Handlebar and steering axle	M8x1.25: (18±2,7)
Upper shock absorber joint	M12x1.25: (60±6)
Lower shock absorber joint	M12x1.25: (60±6)
Rear disc	M8x1.25: (35±3,5)
Swingarm	M14x1.25: (75±7,5)



## Maintenance Schedule

You must service and maintain the motorcycle as shown in the table below.



### TIP:

1. If you ride in a dusty area, you will need to clean the vehicle more frequently.
2. Once the mileage exceeds the limits in the table, continue maintenance at the indicated frequency.

Element	Interval	Km x 1000						
		1	5	10	15	20	25	30
Engine oil	First service at 1,000 km, second at 5,000 km, and thereafter every 5,000 km							
Oil filter cartridge	Replace at the same time as engine oil							
Engine oil level		I	I	I	I	I	I	I
Fuel lines		I	I	I	I	I	I	I
Fuel pump				I		I		I
Fuel filter				R		R		R
Throttle body					C			C
Coolant level		I	I	I	I	I	I	I
Coolant	2 years							R
Air intake system sealing		I	I	I	I	I	I	I
Valve clearance					I			I
Spark plug electrode gap			I	I	R	I	I	R



Air filter element		I	C	R	C	R	C	R
Accelerator operation		A	A	A	A	A	A	R
Clutch		A	A	A	A	A	R	A
Lubrication and tightening of steering bearings		I		L	U	L	I	L
Lubrication of front and rear wheels and sprocket carrier bearings			L	L	L	L	L	L
Lubrication of control shafts and footrests			L	L	L	L	L	L
Lubrication of side stand shaft			L	L	L	L	L	L
Lubrication of brake and clutch levers			L	L	L	L	L	L
Lubrication of rear suspension linkage			L	L	L	L	L	L
Lubrication of swingarm bearings			L	L	L	L	L	L
Lubrication and tension of the chain		A	A	A	R	A	A	R
Battery		I	I	I	I	I	I	I
Brake hoses		I	I	I	I	I	I	I
Brake fluid	2 years	I	I	I	I	I	I	I
Brake fluid level		I	I	I	I	I	I	I
Brake pads		I	I	I	R	I	I	R
Brake light switches		I	I	I	I	I	I	I
Fuel vapour evaporation system		I	I	I	I	I	I	I
Joint tightness		I	I	I	I	I	I	I
Suspension leaks		I	I	I	I	I	I	I
Rims		I	I	I	I		I	I

Legend: I: Inspect, clean, adjust, lubricate, or replace. C: Clean. R: Replace. A: Adjust. L: Lubricate



### **Introduction to electric start**

The electric starter on this motorcycle is a new model designed and developed based on the theoretical principles of motorcycle ignition, with improved electrical components.

This model uses an electric starter that only operates with 12V 6Ah batteries. The clutch lever switch for starting up is mounted on the lever bracket and connected to the left handlebar switch assembly. The engine can only be started in neutral while pulling the clutch lever.

The electric start button is located on the right handlebar switch assembly.

To start the motorcycle, turn the ignition key to the “ON” position, make sure the emergency switch is in the correct position, and then press the electric start button .

If you attempt to start for more than 5 seconds, release the starter motor and wait a few seconds before trying again.

For easier use and maintenance, please see the electrical diagram on the next page.



## EFI injection system diagram

1. Battery
2. Instrument dashboard
3. ECU
4. Fuel pump relay
5. Fuel pressure regulator
6. Fuel pump
7. Fuel filter
8. Injector
9. Ignition coil
10. Spark plug
11. Sensor
12. Idle speed controller
13. Canister
14. Throttle body
15. Crankshaft position sensor
16. Coolant temperature sensor
17. Lambda probe
18. Silencer (with catalytic converter)
19. Diagnostic connector
20. Fuel tank
21. Air filter

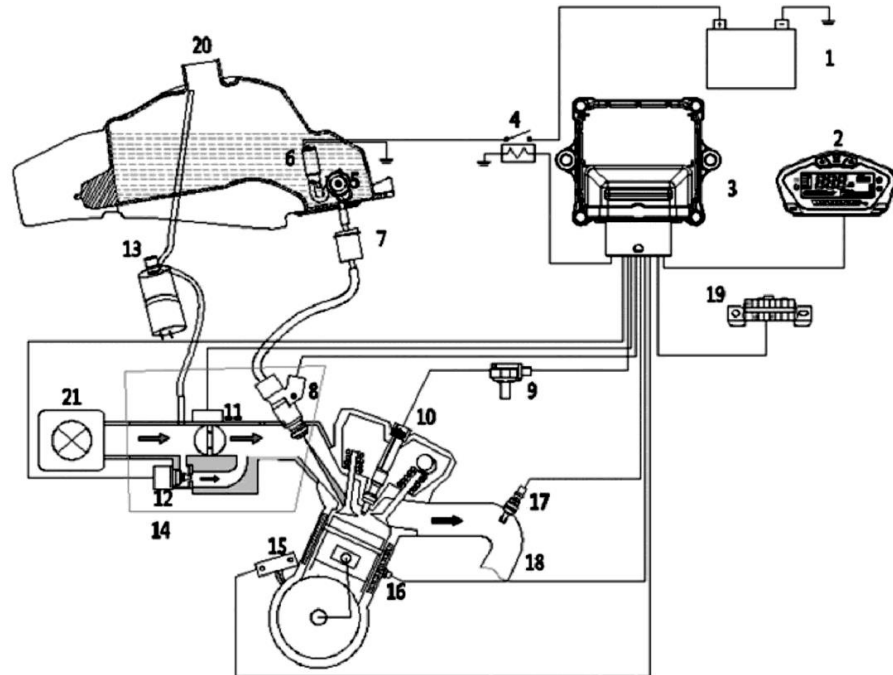



### **EFI injection system operation and maintenance**

When you start the motorcycle for the first time, we recommend turning the ignition key from OFF to ON three times, keeping it ON for 5 seconds each time before starting. This helps to purge any gases trapped in the fuel system and increase fuel pressure.

For normal use after the first start, we recommend starting the engine after the fuel pump has done its job (about 5 seconds after turning the key to ON) to ensure adequate fuel pressure before ignition.

After one year of use, or once the maintenance interval indicated in the maintenance table has been reached (see section), the fuel filter must be replaced and the throttle body cleaned.



## VEHICLE STORAGE AND CLEANING

### Vehicle storage

If your motorcycle will not be used for an extended period, special maintenance is required and certain materials, tools, and technical expertise are necessary. We therefore recommend that these operations be performed at an authorised **RIEJU** dealer.

If you wish to carry out these procedures yourself, please follow the methods described as follows:

- Completely replace the oil with new oil.
- Block the air filter intake and the exhaust outlet with a cloth soaked in clean oil to prevent humid air from entering the engine.
- Completely drain all the fuel from the fuel tank.
- Remove the battery, clean its surface with neutral soapy water, and remove any rust from the positive and negative terminals.
- Store the battery in a room at a temperature above 0 °C.



- ☒ Adjust the tyre pressure to the specified value.
- ☒ Thoroughly wash the vehicle.
- ☒ Spray a rubber protectant on the surface of all rubber parts.
- ☒ Coat the entire vehicle with automotive protective wax.
- ☒ Finally, cover the vehicle with a cloth and store it in a dry, well-ventilated area.

**CAUTION:**

- Recharge the battery you have removed once per month.



## How to reactivate the vehicle

- ☒ Thoroughly clean the vehicle.
- ☒ Remove the cloths from the air filter intake and the exhaust outlet.
- ☒ Completely replace the engine oil and oil filter.
- ☒ Install the battery.
- ☒ Start the vehicle.



## Vehicle protection

Depending on how you use it, wash the vehicle frequently and keep it clean and dry.

Remove any dirt or residues such as bird droppings, asphalt, or salt from the surface as soon as possible.

Attempt to use a vehicle cover. Prolonged exposure to sunlight may cause ageing and discolouration of exterior parts.

## Cleaning the vehicle

Wash the vehicle with cold water.

Clean thoroughly with a soft cloth and neutral detergent.

Do not spray water directly onto the vehicle.

Do not wash the vehicle with high-pressure water.



On rainy days or after washing the motorcycle, a small amount of moisture may appear as fog inside the headlamp or indicator. Simply turn on the lights for a while and the moisture will disappear. This is normal since the lamps are designed with ventilation holes.



**CAUTION:**

The braking performance of wet brakes is reduced. Test the braking system repeatedly at low speed after washing to dry it quickly.



**CAUTION:** Do not apply de-greaser to the wheel axles or the chain.



**CAUTION: RIEJU** accepts no responsibility for the use of corrosive degreasers that may stain or damage motorcycle parts. **RIEJU** is not liable for any damage or defects caused by using high-pressure water to clean the motorcycle.



## MODIFICATIONS AND ACCESSORIES

Only use original **RIEJU** parts and accessories.

You can obtain genuine parts, accessories, and other **RIEJU** products through authorised dealers. At the same time, professionals will advise you on installation and use.

The safety, performance, and compatibility of these parts and products have been tested and are guaranteed. On the other hand, no responsibility will be accepted for unauthorised parts or accessories.

Whenever you plan to replace parts, ensure compliance with all laws and regulations so that your vehicle meets national road vehicle requirements and other legal and technical specifications.



### CAUTION:

- The unauthorised modification of components, such as the electronic control system, may cause vehicle damage and accidents.



## WARRANTY

Standards regulating manufacturer **RIEJU'S** warranty.

The company **RIEJU** hereby guarantees the end consumer, purchaser of a vehicle manufactured by **RIEJU**, that both the materials and the manufacturing are free from defect, pursuant to the highest quality standards. Consequently, **RIEJU** hereby provides the end purchaser (hereinafter, the “purchaser”), pursuant to the conditions set forth below, with a warranty to repair all material or manufacturing defects found on a new motorcycle at no cost, within the established warranty period and with no limitation in terms of the number of kilometres travelled or the number of hours the vehicle has been operated.

### Warranty Period

The warranty period shall be governed by warranty law in the vehicle's country of sale, in force at the time it is sold.



Warranty claims for defects not brought to the attention of a **RIEJU**-authorised dealer before the end of the warranty period shall be excluded.

### Purchaser obligations

**RIEJU** may legitimately reject warranty claims if, and to the extent that:

- a) The purchaser has not brought the vehicle to any of the inspections and/or to undergo maintenance tasks as required in the user manual, or the date set for these inspections or maintenance tasks has passed. Also excluded from the warranty are defects that appear before the date established for an inspection or



maintenance task that never occurred, or that will occur after the established date.

b) Inspections, maintenance work, or repairs have been conducted by third parties not recognised or authorised by **RIEJU**.

c) Any maintenance or repair has been conducted in violation of the technical requirements, specifications, and instructions set forth by the manufacturer.

d) Replacement parts not authorised for use by **RIEJU** have been used in maintenance or repair work on the vehicle, or if, and to the extent that, fuels, lubricants, or other liquids (including, but not limited to, cleaning products) that were not expressly mentioned in the User Manual's instructions have been used on or in the vehicle.

e) The vehicle has been, in any way, altered or modified or fitted with components other than the components expressly authorised by **RIEJU** as components allowed for the vehicle.

f) The vehicle has been stored or transported in a way that is contrary to technical requirements.

g) The vehicle has been used for a special use other than ordinary use, such as competition, racing, or in an attempt to beat a record.

h) The vehicle has suffered a fall or accident that directly or indirectly causes damages.

### **Warranty exclusions**

The following articles are excluded from the warranty:

a) Replacements for wear, including, but not limited to, spark plugs, batteries, fuel filters, oil filter elements, chains (secondary), engine output pinions, rear rings, air filters, brake discs, brake pads, clutch disks, bulbs, fuses, carbon brushes, footrest rubber, tyres, chambers, wires, and other rubber components, ex-



haust pipe, and washers.

b) Lubricants (for example, oil, grease, etc.) and operational fluids (for example, battery fluid, coolant, etc.).

c) Inspection, adjustment, and other maintenance work, as well as all kinds of cleaning work.

d) Damage to the paint and consequent rust due to external influences, such as rocks, salt, industrial fumes, and other environmental impacts, or inadequate cleaning with inadequate products.

e) Damages caused by defects, as well as expenses caused directly or indirectly by the defects (for example, communications expenses, lodging expenses, car hire expenses, public transport expenses, recovery vehicle expenses, emergency messenger expenses, etc.) as well as other financial harm (for example, caused by loss of use of a vehicle, lost income, lost time, etc.).

f) Acoustic or aesthetic circumstances that do not significantly affect conditions for use of the motorcycle (for example, small or hidden imperfections, normal noise or vibration in use, etc.).

g) Circumstances due to vehicle ageing (for example, fading of painted surfaces or metal coating).

### Miscellaneous

a) If repair of the defect or replacing the part is disproportionate, **RIEJU** shall be entitled to decide, at its sole discretion, whether to repair or replace the defective parts. Ownership over the replaced parts, if applicable, shall be held by **RIEJU**, with no other consideration. The dealer authorised by **RIEJU** whom has been entrusted to repair defects shall not be authorised to make binding statements on **RIEJU'S** behalf.

b) If there is doubt as to whether there is a defect or a visual or material inspection is required, **RIEJU** reserves the right to require that the parts being claimed under the warranty be sent to it, or to request that a **RIEJU**



expert examine them. Any additional warranty obligations for replaced parts at no cost or for any services provided at no cost under this warranty shall be excluded. The warranty for replaced components during the warranty period shall end on the expiry date of the warranty period of the respective product.

c) If a defect cannot be repaired and its replacement is disproportionate for the manufacturer, the consumer under warranty shall be entitled to cancellation of the contract (payment of a compensation) or partial reimbursement of the purchase price (discount) instead of motorcycle repair.

d) The purchaser's warranty claims under the purchase-sale contract with the authorised dealer shall not be affected by this warranty. This warranty shall not affect the purchaser's additional contractual rights under the general business conditions of the authorised dealer. However, said additional rights may only be claimed with the authorised dealer.

e) If the purchaser resells the product during the warranty period, the terms and conditions of this warranty shall continue to exist under their current scope, such that rights to claim pursuant to this warranty under the terms and conditions governed by this document shall be transferred to the new owner of the motorcycle.



**RIEJU**

FOR EVERYDAY ADVENTURE